

T-2500HFE PRECISION TEMPERATURE FORCING SYSTEM

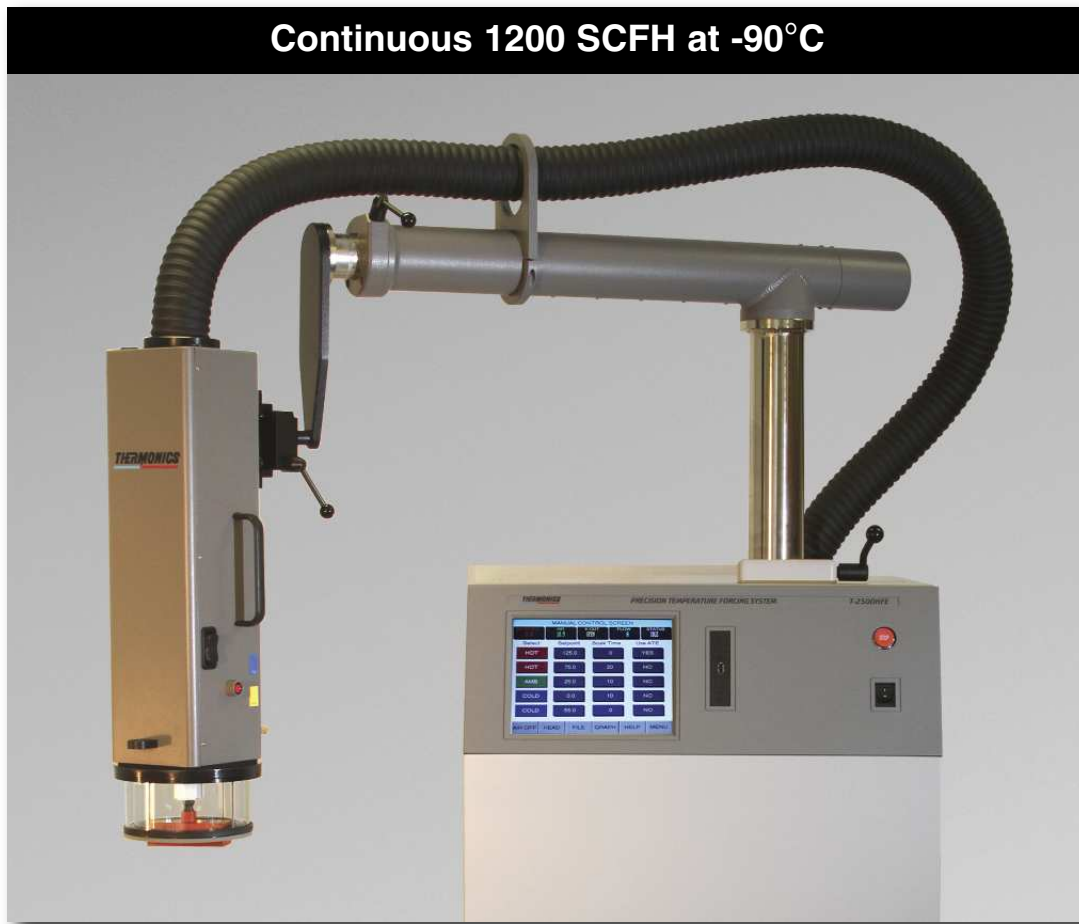

T-2500HFE PTFs

To meet the industry's growing requirement to test and characterize fast, high power devices; Thermionics has developed the T-2500HFE Precision Temperature Forcing System. Capable of sustaining a continuous high flow rate of 1200 SCFH (9.4 liters/sec) at -90C, the unit can easily accommodate the testing and thermal cycling of high-clock-speed, high wattage devices.

A wide temperature range of -90C to +225C and fast transition time (+125C to -55 in four seconds) provide an ideal test system to meet this growing demand for testing such devices in a quick, economical, and efficient manner. Additionally, the high flow rate capability of the T-2500HFE is of great benefit when used in conjunction with large thermal test fixtures and enclosures for rapidly transitioning the environment to temperature in a precise manner.

Precise Temperature Control

Thermionics' patented temperature control algorithm enables the T-2500HFE to provide accelerated, high-precision temperature regulation. Temperature resolution is 0.1C and accuracy is $\pm 1.0C$. The high air flow rate enables rapid transition to test temperatures and enhanced thermal cycling. Physical integration of the Device Under Test (DUT) is facilitated with an interface kit which includes variously sized thermal boots and a glass shroud assembly. Alternatively-sized thermal boots, shrouds, and customized thermal fixtures are available when a larger, temperature-controlled environment is required.

Sophisticated Temperature Cycling

The system may be used for temperature cycling per MIL STD-883C specifications for thermal stressing of semiconductor devices. Complex temperature profiles are easily set up via the touch screen display. Profile parameters entered can be as complex as 99 discrete steps. Profiles can be saved and recalled for later use, or exported to a USB data storage device.

Integrated Thermal Test Head and Motorized Arm

The fully-motorized arm provides a reliable and strong support for adapting the thermal test head to the DUT. The positive action, quick to adjust arm has several degrees of freedom the enables it to be positioned in a wide range of horizontal and vertical positions. A combination of electro-mechanical and pneumatic action ensures precise, stable and repeatable placement of the thermal test head over the DUT. Additionally, temperature-controlled purge air is used to keep the test interface free of frost and moisture when testing at cold temperatures.

Service and support for the T-2500HFE is available worldwide. Whether you are in the USA, Asia or Europe, a qualified technician can service the system quickly and efficiently. Support is always available from the factory via telephone, web-form or email.

1288 Reamwood Ave.
Sunnyvale, CA 94089-2233
(408) 542-5900 Fax: (408) 542-5910
E-mail: info@thermonics.com
URL: www.thermonics.com

THERMONICS
AN INTEST COMPANY

T-2500HFE Specifications

The model T-2500HFE PTF5 is designed to comply with the following specifications. The systems has been factory tested to verify conformance.*

FEATURES

- **Fast temperature response time**
- **Environmentally safe**
- **Fully grounded**
- **Small footprint**
- **Fast DUT temperature stabilization time**
- **Color LCD with touch-screen**
- **Flexible ATE communications**
- **Sophisticated system self diagnostics**
- **±1C accuracy with 0.1C readout**
- **High air flow rate**
- **Frost free operation**
- **Graphical display of temperature response**

GENERAL DESCRIPTION

Method of Cooling: Forced air with single-stage mechanical refrigeration and multi-stage self-cooling heat exchanger. Non-CFC based refrigerants are used - environmentally safe.

Method of Heating: Forced air with in-line air heaters.

Operator Interface: Color LCD. GUI with menu-driven touch-screen using software menu selections. Software contains system self-diagnostics. Uses graphical software to select system menus such as operating mode, and to set system parameters such as temperature setpoint or flow rate.

Data Communications: Interfaces to ATE systems. Contains IEEE-488.2, RS-232C, Standard Tester Interface, and Printer port. Software communication parameters are configurable to accommodate varying systems.

SYSTEM FEATURES

Temperature sensor: Device Under Test (DUT), K-type and T-Type thermocouples. Also, K-type thermocouple for air temperature.

Controller: Core Duo® -based PC motherboard.

Fail safes: Firmware independent temperature failsafe PCB with redundant over-temperature sensors and air-flow sensor.

Motorized Arm: Fully motorized using a combination of electro-mechanical and pneumatic action. Ensures precise, stable and repeatable placement of the thermal test head over the DUT.

TEMPERATURE PERFORMANCE

	Range (°C)	Accuracy (°C)	Stability (°C)	Displayed Resolution (°C)	Transition** Time (sec)
T-2500HFE	-90 – 225	±1.0	±0.3	0.1	10

Maximum cold specifications are for room ambient temperature of 77°F (25°C), or lower, using 60Hz power. Cold temperature specifications are degraded 5C for 50Hz operation. **Transition time is between +125°C and -55°C; air temperature measured at air output nozzle. Measured in temperature cycle mode after system stabilization with a 10-second soak time, or less, at each temperature.

ENVIRONMENTAL REQUIREMENTS

Ambient Temperature Range: 15°C to 26°C
Relative Humidity: 20 - 65%

POWER REQUIREMENTS

Volts	Hertz	Phases	Amps
200 – 230	50/60	1ø	30

AIR INPUT REQUIREMENTS

Pressure: 80-110 PSIG (5.7 - 7.8 Kg/Cm²)

Flow Rate: 30 SCFM (14.2 liters/sec)

Dew Point: Less than 10C at 80 PSIG (5.7 Kg/Cm²)

Quality: Clean air; free of oil, moisture and particles

OUTPUT AIR FLOW

200 to 1200 SCFH (1.6 to 9.4 liters/sec.). Flow is under software control.

PHYSICAL CHARACTERISTICS

Height (in/cm)	Width (in/cm)	Depth (in/cm)	Weight (lbs/kgm)
55/139	25/63	28/71	655/295



*Specifications subject to change without notice.
© 1/2012 Thermionics
® Core Duo is a registered trademark of Intel Corporation.
Printed in U.S.A.

1288 Reamwood Ave.
Sunnyvale, CA 94089-2233
(408) 542-5900 Fax: (408) 542-5910
E-mail: info@thermonics.com
URL: www.thermonics.com

THERMONICS
AN INTEST COMPANY

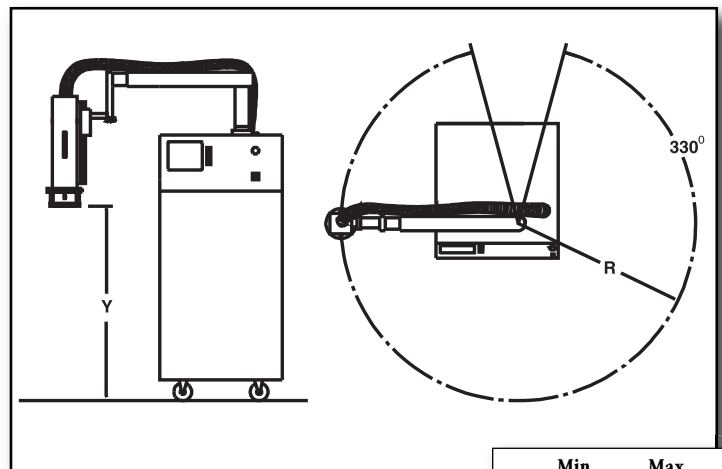

	Min (in/cm)	Max (in/cm)
Y	27/69	44/112
R	34/86	48/122